



IMPORTANT: Fill in Pertinent Information on Page 3 for Future Reference

Table of Contents

Job Specification Sheet.....	3
Timer Operation.....	4
Master Programming Mode Flow Chart.....	8
Master Programming Mode.....	13
User Programming Flow Chart & Mode.....	18
Diagnostic Programming Mode Flow Chart.....	19
Diagnostic Programming Mode.....	20
2510/2750 & 2850 Power Head Assy.....	22
2900s Power Head Assy.....	24
3150 Power Head Assy.....	26
3900 Power Head Assy.....	28
9000 / 9100 / 9500 Power Head Assy.....	30
2750XT/2850XT & 9000/9100/9500 Wiring.....	32
2900XT Wiring.....	33
3150XT Wiring.....	34
3900XT Wiring.....	35
Troubleshooting - Timer.....	36



IMPORTANT PLEASE READ:

- The information, specifications and illustrations in this manual are based on the latest information available at the time of printing. The manufacturer reserves the right to make changes at any time without notice.
- This manual is intended as a guide for service of the valve only. System installation requires information from a number of suppliers not known at the time of manufacture. This product should be installed by a plumbing professional.
- This unit is designed to be installed on potable water systems only.
- This product must be installed in compliance with all state and municipal plumbing and electrical codes. Permits may be required at the time of installation.
- If daytime operating pressure exceeds 80 psi, nighttime pressures may exceed pressure limits. A pressure reducing valve must be installed.
- Do not install the unit where temperatures may drop below 32°F (0°C) or above 125°F (52°C).
- Do not place the unit in direct sunlight. Black units will absorb radiant heat increasing internal temperatures.
- Do not strike the valve or any of the components.
- Warranty of this product extends to manufacturing defects. Misapplication of this product may result in failure to properly condition water, or damage to product.
- A prefilter should be used on installations in which free solids are present.
- In some applications local municipalities treat water with Chloramines. High Chloramine levels may damage valve components.
- Correct and constant voltage must be supplied to the control valve to maintain proper function.

Job Specification Sheet

NOTE: Some options may not be available depending on valve model or other options chosen.

Circle and/or Fill in the Appropriate Data for Future Reference.

System Type: Meter Immediate / Time Clock Delayed / Twin Tank / Volume Override Delay
Volume Override Immediate / Remote Signal Start Delayed
Remote Signal Start Immediate / Meter Delayed Week Reserve
Meter Delayed Variable Reserve / Meter Delay Fixed Reserve

Valve Type: 2510/2850 2750 2900 3150 3900 9000/9100/9500 Proprietary A B E

Regenerant Flow: Down Flow / UF Variable Fill / UF Brine First
Downflow DB BW / UF Backwash / Back Wash Filter

Initial Tank: Tank 1 or Tank 2

Remote Signal Start: On or Off

Display Format: U.S. or Metric (French Degrees, German Degrees, or PPM)

Unit Capacity: _____ Grains/French Degrees/German Degrees/PPM

Water Hardness: _____ Grains/French Degrees/German Degrees/PPM

Capacity Safety Factor: Zero or _____ %

Volume Override: _____ (Gallons or M³)

Regeneration Day Override: Off or Every _____ Days

Regeneration Time: Delayed _____ AM/PM or _____ Immediate

Regeneration Cycle Step #1: __ : __ : __
Regeneration Cycle Step #2: __ : __ : __
Regeneration Cycle Step #3: __ : __ : __
Regeneration Cycle Step #4: __ : __ : __
Regeneration Cycle Step #5: __ : __ : __

Media Volume: _____ (CuFt or Liter)

Salt Dosage: _____ (lbs/CuFt or grams/Liter)

BLFC Size: _____ gpm

Auxiliary Relay: Enabled or Disabled

Auxiliary Relay Start 1: __ : __ : __
Auxiliary Relay End 1: __ : __ : __
Auxiliary Relay Start 2: __ : __ : __
Auxiliary Relay End 2: __ : __ : __

Chemical Pump: Enabled or Disabled

CPO Aux Relay Volume: _____ (Gallons or M³)

CPO Aux Relay: __ : __ : __

Flow Meter Size: Paddle: .75" 1.0" 1.5" 2.0" 3.0"
Turbine: .75" 1.0" 1.5"

Generic Flow Meter: Maximum Flow Rate: Add __ Gallons every __ Pulses

Timer Operation

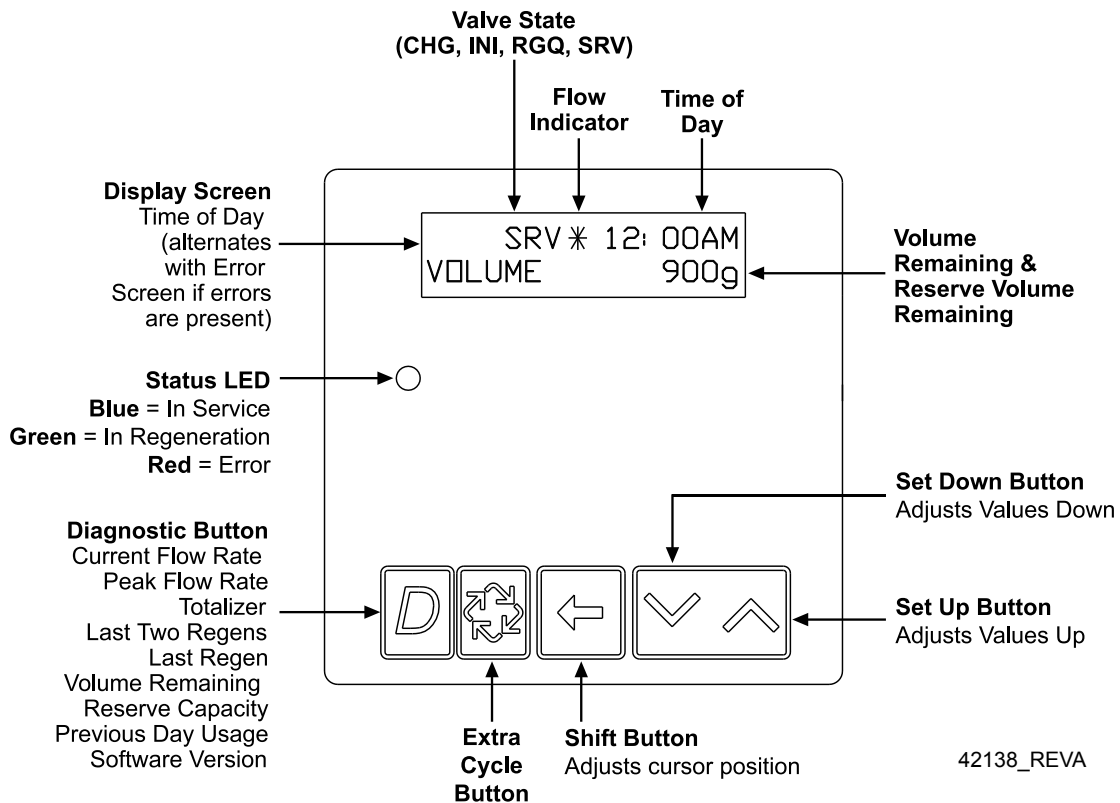

Valve State:

CHG (Change of State)

CHG will be displayed when the lower drive changes from one state to another in dual piston valves.

INI (Initializing)

INI will display on the screen for 30 to 45 seconds when initializing after a power failure reset or programming.

RGQ (Regeneration Queued)

RGQ indicates that the reserve has been entered in a delayed system and regeneration has been queued. When in the main screen, press the Shift button to toggle service (SRV) with RGQ.

Service (SRV)

SRV will display when the unit is in service.

LED Status Lights:

Blue LED:

Illuminates while the unit is in service and no errors exist. The unit will always be in service unless a regeneration trigger has occurred (green LED light will be displayed).

Green LED:

Illuminates when the unit is in Regeneration mode, unless an error condition exists.

Red LED:

Illuminates when there is an error.

Flow Indicator:

A rotating line (appearing as a rotating star shape) will display on the screen when flow is going through the meter.

Timer Operation

Regeneration:

- A time initiated control valve regenerates when the number of programmed days has been reached
- A flow initiated control valve regenerates when the volume count is zero or is below reserve capacity

System Type	Regeneration Trigger
Time Clock Delayed	A) Day override parameter is reached and B) the time of day matches the regeneration day override time
Meter Immediate	Regenerates as soon as the volume remaining has been depleted
Meter Delayed Fixed Reserve	A) Volume remaining has been depleted to the fixed reserve volume and B) the regeneration time has been reached
Meter Delayed Variable Reserve	A) Volume remaining has been depleted to the variable reserve volume and B) the regeneration time has been reached
Meter Delayed Weekly Reserve	A) Volume remaining has been depleted to the weekly variable reserve volume and B) the regeneration time has been reached
Remote Signal Start Immediate	Immediately once a valid remote signal is asserted continuously for the programmed period of time
Remote Signal Start Delayed	Once a valid remote signal is asserted continuously for the programmed period of time and regeneration time has been reached
Volume Override Immediate	As soon as the programmed volume remaining has been depleted from the tank
Volume Override Delayed	As soon as soon as the programmed volume remaining has been depleted from the tank and the regeneration time has been reached
Twin Tank	Regenerates immediately once volume remaining has been depleted

Timer Operation

Setting the Time of Day

1. Press and hold the Up or Down button for 2 seconds.
2. Press the Shift button to select the digit you want to modify.
3. Press the Up or Down buttons to adjust the value.
4. Press the Extra Cycle button to return to the normal display screen, or after a 5 second timeout.

NOTE: The “D” button (Diagnostic) can be pressed to exit without saving.

Manually Initiating a Regeneration

1. When timer is in service, press the Extra Cycle button for 5 seconds on the main screen.
2. The timer advances to Regeneration Cycle Step #1, and begins programmed time count down.
3. Press the Extra Cycle button once to advance valve to Regeneration Cycle Step #2 (if active).
4. Press the Extra Cycle button once to advance valve to Regeneration Cycle Step #3 (if active).
5. Press the Extra Cycle button once to advance valve to Regeneration Cycle Step #4 (if active).
6. Press the Extra Cycle button once to advance valve to Regeneration Cycle Step #5 (if active).
7. Press the Extra Cycle button once more to advance the valve back to in service.

NOTE: A manually initiated or queued regeneration can be cleared by pressing the Extra Cycle button for less than 5 seconds. A system queued regeneration can only be cleared by stepping through a manual regeneration. If regeneration occurs for any reason prior to the delayed regeneration time, the manual regeneration request shall be cleared. Pressing the Extra Cycle button while in regeneration will cause the upper drive to advance to the next step immediately.

Queued Regeneration (RGQ)

From the display screen, while the unit is in service, hold down the Extra Cycle button until “RGQ” displays. The valve will regenerate when the set regeneration time has been reached.

Timer Operation During Regeneration

In the main display screen, the timer shows the current regeneration cycle and the time for that step. The **green LED light** will display when the unit is in regeneration. Once all regeneration steps are complete, the timer returns to in service, displays a **blue LED light**, and resumes normal operation.

Timer Operation During Programming

The timer enters program mode (unit must be in service). While in the program mode the timer continues to operate normally, monitoring water usage. Timer programming is stored in memory permanently upon a normal exit from programming mode.

Timer Operation During A Power Failure

All program settings are stored in permanent memory. Current valve position, cycle step time elapsed, and time of day are stored during a power failure, and will be restored upon power re-application. Time is kept during a power failure, and time of day is adjusted upon power up (as long as power is restored within 12 hours).

NOTE: The time of day on the main display screen will flash for 5 minutes when there has been a power outage. The flashing of the time of day can be stopped by pressing any button on the display.

Regeneration Day Override Feature

If the Day Override option is turned on and the valve reaches the set Regeneration Day Override value, the Regeneration Cycle starts at the programmed regeneration time.

Flow Meter Equipped Timer

As treated water is used, the Volume Remaining display counts down from the calculated system capacity, less the reserve volume. Once capacity reaches zero or reserve, if the immediate system the unit will regenerate immediately. If it is a Fixed, Variable, or Weekly reserve, the unit will queue a regeneration (RGQ) and count down Reserve Volume until the set regeneration time.

NOTE: Reserve Volume is only available in a RGQ system.

Volume Remaining (Less Reserve)

SRV * 08:45AM
VOLUME 1000G

Reserve Volume

RGQ * 09:32AM
VOLUME 100G

Master Programming Mode Flow Chart

NOTE: Depending on current option settings, some displays cannot be viewed or set.

To Set Time of Day:

Press and hold the Up or Down buttons for 2 seconds. Press the Shift button to select the digit you want to modify.



Entering Master Programming Mode:

1. Press and hold the Shift and Up buttons for 5 seconds.
OR
2. Set the Time of Day display to **12:01 P.M. or 12:01HR**. Then go to the main display screen, press the Up and Down buttons at the same time for 5 seconds.

NOTE: Only shown when System Type is Twin Tank

NOTE: Only shown when System Type is Remote Signal Start



S	Y	S	T	E	M	T	Y	P	E	:				
T	I	M	E	C	L	K	D	E	L	A	Y	E	D	

Options: Time Clock Delayed [TIME CLK DELAYED] (Default)
 Meter Immediate [METER IMMEDIATE]
 Meter Delayed Fixed Reserve [MTR DLY FIX RSV]
 Meter Delayed Variable Reserve [MTR DLY VAR RSV]
 Meter Delayed Week Reserve [MTR DLY WEEK RSV]
 Remote Signal Start Immediate [RSS IMMEDIATE]
 Remote Signal Start Delayed [RSS DELAYED]
 Volume Override Immediate [VOL OVERRIDE IMM]
 Volume Override Delayed [VOL OVERRIDE DLY]
 Twin Tank [TWIN TANK]



V	A	L	V	E	T	Y	P	E	:					
					2	5	1	0	/	2	8	5	0	

Options: 2510/2850 [2510/2850] (Default)
 2750 [2750]
 2900 [2900]
 3150 [3150]
 3900 [3900]
 9000/9100/9500 [9000/9100/9500]
 Proprietary A [PROPRIETARY A]
 Proprietary B [PROPRIETARY B]
 Proprietary E [PROPRIETARY E]



R	E	G	E	N	E	R	A	N	T	F	L	O	W	:
D	O	W	N	F	L	O	W							

Options: Down Flow [DOWN FLOW] (Default)
 Back Wash Filter [BACK WASH FILTER]
 Up Flow [UP FLOW]
 Up Flow Variable Fill [UF VARIABLE FILL]



I	N	I	T	I	A	L	T	A	N	K	:			
							T	A	N	K		1		

Options: Tank 1 [TANK 1] (Default)
 Tank 2 [TANK 2]



R	E	M	O	T	E	S	I	G	N	A	L	:		
S	T	A	R	T	:		0	:	0	1	:	0	0	

Options: Remote Signal Start [0:01:00] (Default)
 Range: 1 second to 10 hours



D	I	S	P	L	A	Y	F	O	R	M	A	T	:		
						U	S	-	G	A	L	L	O	N	S

Options: Grains per Gallon [US-GALLONS] (Default)
 French Degrees [METRIC - M3, F°TH]
 German Degrees [METRIC - M3, G°TH]
 Parts per Million [METRIC - M3, PPM]



CAUTION: Before entering Master Programming, please contact your local professional water dealer.

Master Programming Mode Flow Chart

NOTE: Depending on current option settings, some displays cannot be viewed or set.

NOTE: Only shown when System Type is Meter Delayed Fixed Reserve or Volume Override Delayed

NOTE: Only shown when System Type is Volume Override Immediate or Volume Override Delayed

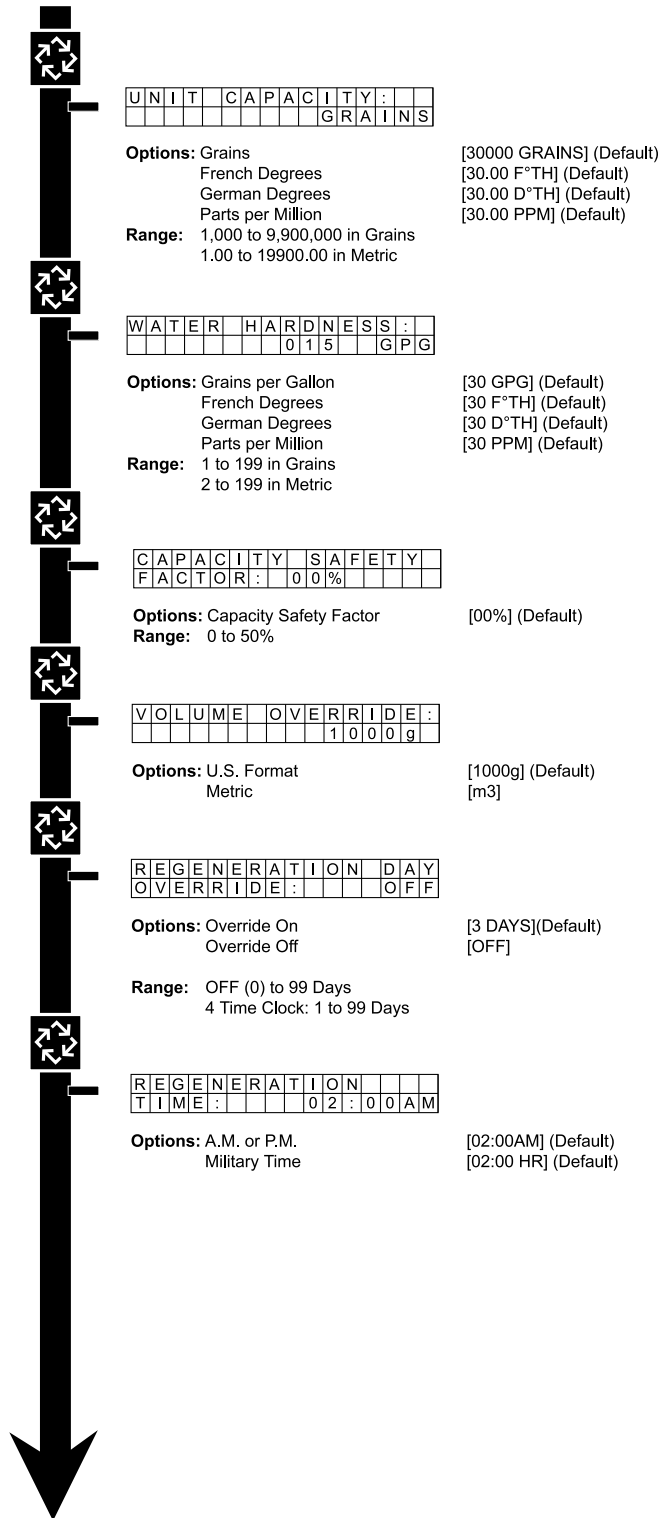

CAUTION: Before entering Master Programming, please contact your local professional water dealer.

Master Programming Mode Flow Chart

NOTE: Depending on current option settings, some displays cannot be viewed or set.

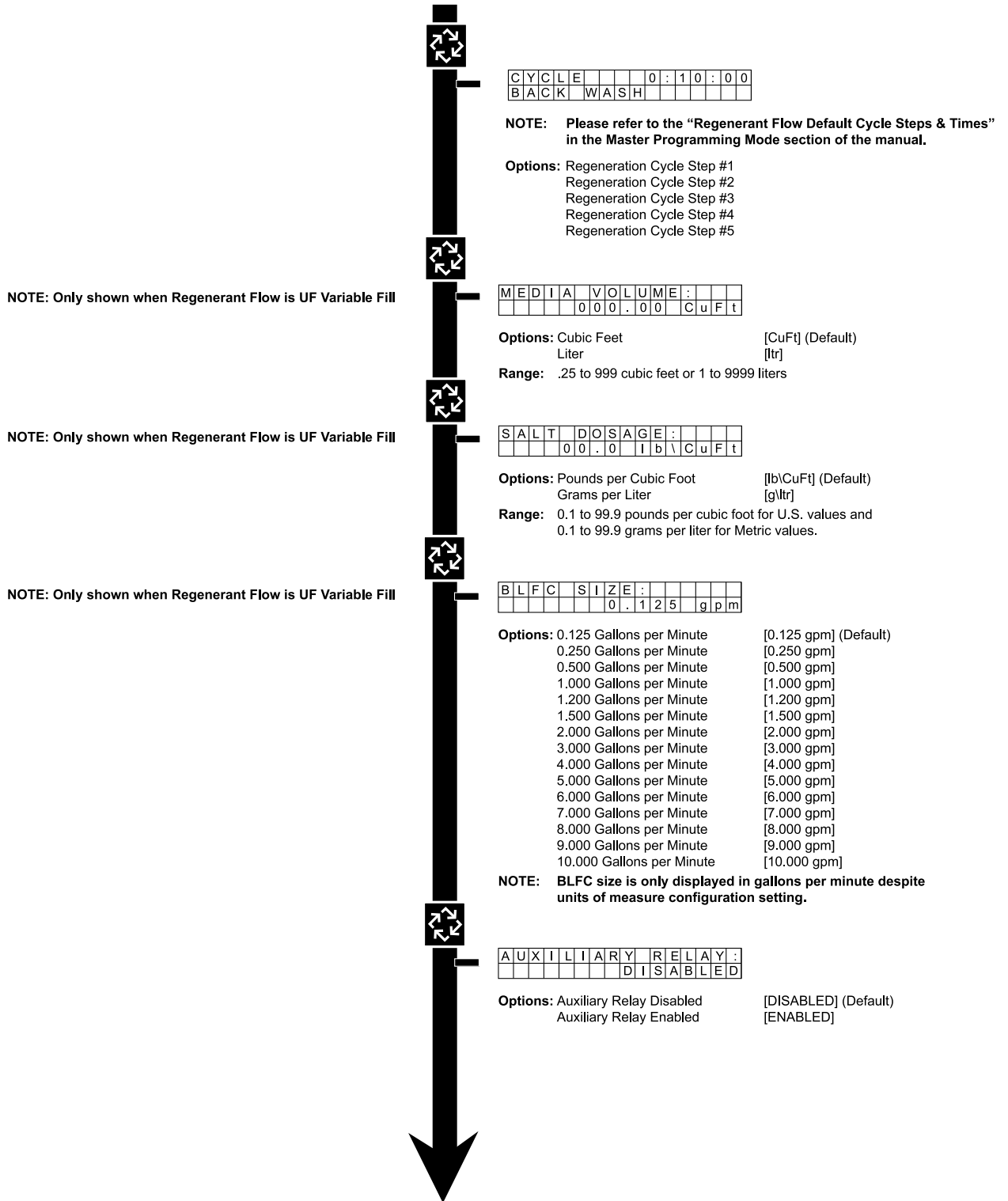

CAUTION: Before entering Master Programming, please contact your local professional water dealer.

Master Programming Mode Flow Chart

NOTE: Depending on current option settings, some displays cannot be viewed or set.

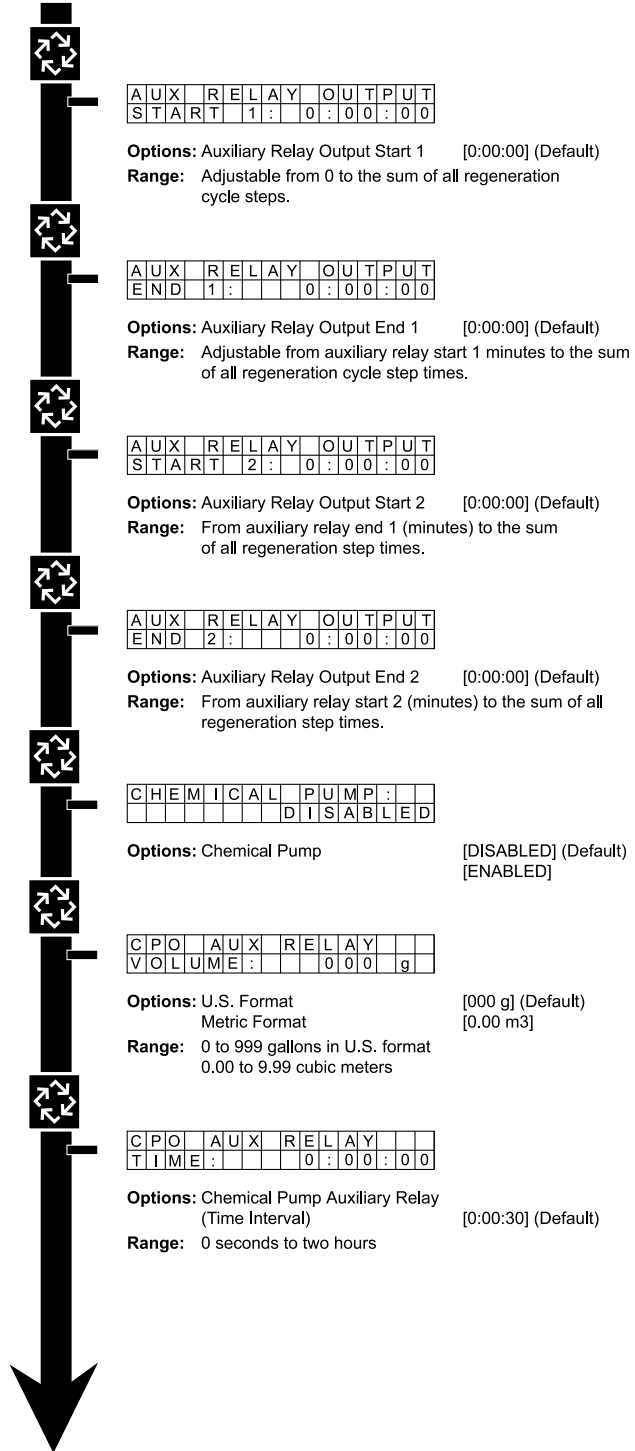

CAUTION: Before entering Master Programming, please contact your local professional water dealer.

Master Programming Mode Flow Chart

NOTE: Depending on current option settings, some displays cannot be viewed or set.

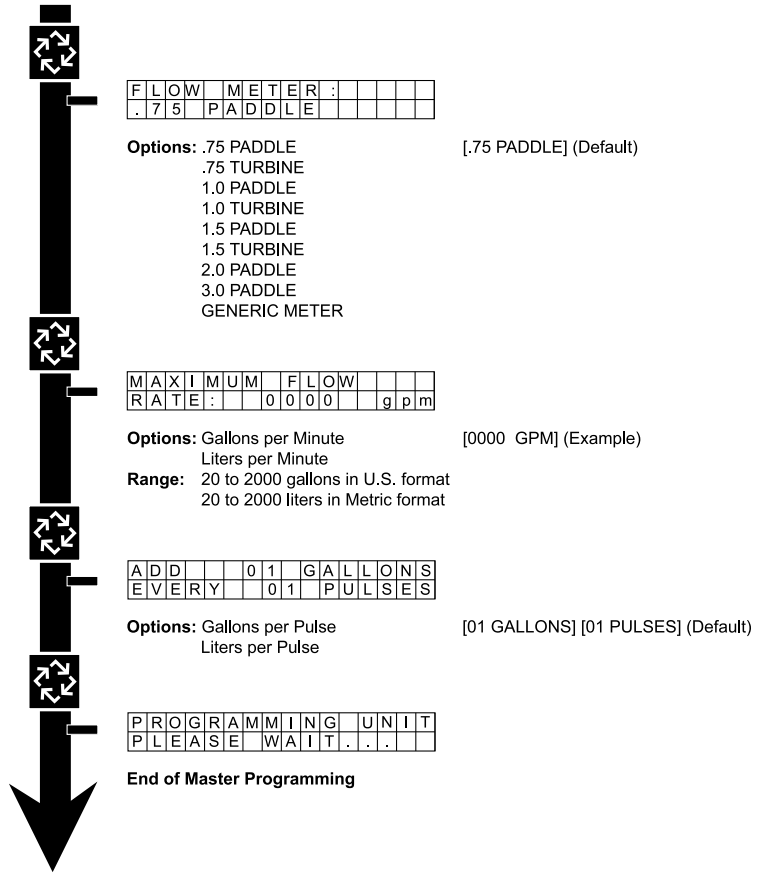

CAUTION: Before entering Master Programming, please contact your local professional water dealer.

Master Programming Mode

When the Master Programming Mode is entered, parameters can be set to make the timer function as needed.

NOTE: Depending on current option settings, some displays cannot be viewed or set.

Entering Master Programming Mode:

1. Press and hold the Shift and Up buttons for 5 seconds.
OR
2. Set the time of day display to **12:01 PM** or **12:01HR** (See the User Programming section to learn how to do this). Then go to the main display screen, press the Up and Down buttons at the same time for 5 seconds.

Exiting Master Programming Mode:

1. Press the Extra Cycle button once per display until all are viewed. Master Programming Mode is exited and the normal display screen appears.
2. To exit the Master Programming Mode without saving, press the Diagnostic button.

NOTE: If no keypad activity is made for 5 minutes while in the Master Programming Mode, or if there is a power failure, no changes will be made, and the unit will go back to the main display screen.

Resets:

Soft Reset: Press and hold the Up and Down buttons for 25 seconds until 12:00PM (or 12:00HR) appears. This resets all parameters except for the flow meter totalizer volume.

Master Reset: Hold the Shift button while powering up the unit. This resets all of the parameters in the unit. Check and verify the choices selected in Master Programming Mode.

1. System Type

This program step selects the system type.

- Press the Up or Down buttons to adjust this value.
- Press the Extra Cycle button.

```
SYSTEM TYPE:  4
TIME CLK DELAYED
```

2. Valve Type

This program step selects the valve type.

- Press the Up or Down buttons to adjust this value.
- Press the Extra Cycle button.

```
VALUE TYPE:
2510/2850
```

3. Regenerant Flow

This program step selects how the regenerant flows through the tank (must match cam). The selections available will vary depending on the previously chosen valve model.

- Press the Up or Down buttons to adjust this value.
- Press the Extra Cycle button.

```
REGENERANT FLOW:
DOWN FLOW
```

CAUTION: Before entering Master Programming, please contact your local professional water dealer.

Master Programming Mode

4. Display Format

This program step selects the display format.

- Press the Up or Down buttons to adjust this value.
- Press the Extra Cycle button.

```
DISPLAY FORMAT:
US - GALLONS
```

5. Unit Capacity

This program step selects the timer's total capacity of hardness that can be removed.

- Press the Shift button to select the digit you want to modify.
- Press the Up or Down buttons to adjust this value.
- Press the Extra Cycle button.

```
UNIT CAPACITY:
0030000 GRAINS
```

6. Feed Water (Hardness)

This program step is used to set the feed water hardness. The system will automatically calculate volume remaining based on the unit capacity, capacity safety factor (reserve systems only), and feed water hardness entered.

- Press the Shift button to select the digit you want to modify.
- Press the Up or Down buttons to adjust this value.
- Press the Extra Cycle button.

```
WATER HARDNESS:
030 GPG
```

7. Capacity Safety Factor

This program step is used to set the reserve capacity of the unit. This is a percentage by which the unit's capacity is reduced.

- Press the Shift button to select the digit you want to modify.
- Press the Up or Down buttons to adjust this value.
- Press the Extra Cycle button.

```
CAPACITY SAFETY
FACTOR: 00%
```

8. Volume Override

This program step is used to set the volume override of the unit.

- Press the Shift button to select the digit you want to modify.
- Press the Up or Down buttons to adjust this value.
- Press the Extra Cycle button.

CAUTION: Before entering Master Programming, please contact your local professional water dealer.

Master Programming Mode

9. Regeneration Day Override

This program step sets the maximum amount of time (in days) the unit can be in service without a regeneration.

- Press the Shift button to select the digit you want to modify.
- Press the Up or Down buttons to adjust this value.
- Press the Extra Cycle button.

```

REGENERATION DAY
OVERRIDE: 01 DAYS
    
```

10. Regeneration Time

This program step sets the time of day for the regeneration to occur in delayed systems.

- Press the Shift button to select the digit you want to modify.
- Press the Up or Down buttons to adjust this value.
- Press the Extra Cycle button.

```

REGENERATION
TIME:      02:00AM
    
```

11. Regeneration Cycle Step Programming

This program step programs the Regeneration Cycle step times 1 through 5. Please refer to the chart below for regenerant flow default cycle steps and times.

```

CYCLE 1 00:10:00
BACK WASH
    
```

Regenerant Flow	Cycle 1	Time	Cycle 2	Time	Cycle 3	Time	Cycle 4	Time	Cycle 5	Time
Down Flow	Back Wash	10 Minutes	Brine & Slow Rinse	1 Hour	Rapid Rinse	10 Minutes	Brine Tank Fill	12 Minutes	N/A	N/A
Back Wash Filter	Back Wash	15 Minutes	Draw	0	Settling Rinse	10 Minutes	Refill	0	N/A	N/A
UF Variable Fill	Brine & Slow Rinse	10 Minutes	Pause & Delay	1 Hour	Variable Rapid Rinse	N/A	Brine Tank Fill	12 Minutes	Rapid Rinse	10 Minutes
Upflow	Brine & Slow Rinse	1 Hour	Back Wash	10 Minutes	Rapid Rinse	10 Minutes	Brine Tank Fill	12 Minutes	N/A	N/A

CAUTION: Before entering Master Programming, please contact your local professional water dealer.

Master Programming Mode

12. Media Volume

This program step sets the volume of the media in the resin tank.

- Press the Shift button to select the digit you want to modify.
- Press the Up or Down buttons to adjust this value.
- Press the Extra Cycle button.

```
MEDIA VOLUME:
  000.00 Cuft
```

13. Salt Dosage

This program step sets the salt dosage in the unit.

- Press the Shift button to select the digit you want to modify.
- Press the Up or Down buttons to adjust this value.
- Press the Extra Cycle button.

```
SALT DOSAGE:
  00.0 lb/Cuft
```

14. Brine Line Flow Control Size

This program step allows the selection of the desired brine line flow control size in the unit (must match physical brine line flow control).

- Press the Up or Down buttons to adjust this value.
- Press the Extra Cycle button.

```
BLFC SIZE:
  0.125 gpm
```

15. Auxiliary Relay Output

The next two displays are part of a series of settings used to program the optional relay output. The first setting turns the output on/off during regeneration only. The second turns the output on during service only, every time a set volume of water used has accumulated.

NOTE: When auxiliary outputs are in the OFF (default) setting, press the Up or Down buttons to set the first setting. Then press the Extra Cycle button to advance to the second setting.

a. Timed Auxiliary Relay Output Window (Start & End Time Setting)

This option setting consists of two displays. The first display sets the turn-on time of the output, referenced to the start of the first regeneration cycle. The second display sets the output turn-off time, referenced again to the start of the first regeneration cycle. An OFF setting cancels this setting. All settings are in minutes and output timing is synchronized with regeneration cycle timing.

Start Time: Any time during regeneration.

End Time: At start time, and anytime during the regeneration cycle.

```
AUXILIARY RELAY:
  DISABLED
```

CAUTION: Before entering Master Programming, please contact your local professional water dealer.

Master Programming Mode

b. Chemical Pump Auxiliary Relay Output Window

This option setting consists of two displays. The first display sets the volume of water flow at which the output turns on. The second display sets the on time (in seconds) of the output.

- Activate output after volume set is reached.
- Press the Shift button to select the digit you want to modify.
- Press the Up or Down buttons to adjust this value.
- Press the Extra Cycle button.

```
CHEMICAL PUMP:
      DISABLED
```

16. Flow Meter Size

This program step sets the size of the flow meter.

- Press the Up or Down buttons to adjust this value.
- Press the Extra Cycle button.

```
FLOW METER:
. 75 TURBINE
```

17. Maximum Flow Rate

This program step sets maximum flow rate of the generic flow meter.

- Press the Shift button to select the digit you want to modify.
- Press the Up or Down buttons to adjust this value.
- Press the Extra Cycle button.

18. Pulses per Gallon/Liter

This program step sets the pulses per gallon/liter for generic flow meters.

- Press the Shift button to select the digit you want to modify.
- Press the Up or Down buttons to adjust this value.
- Press the Extra Cycle button.

19. End of Master Programming Mode

CAUTION: Before entering Master Programming, please contact your local professional water dealer.

User Programming Flow Chart & Mode

NOTE: Depending on current option settings, some displays cannot be viewed or set.

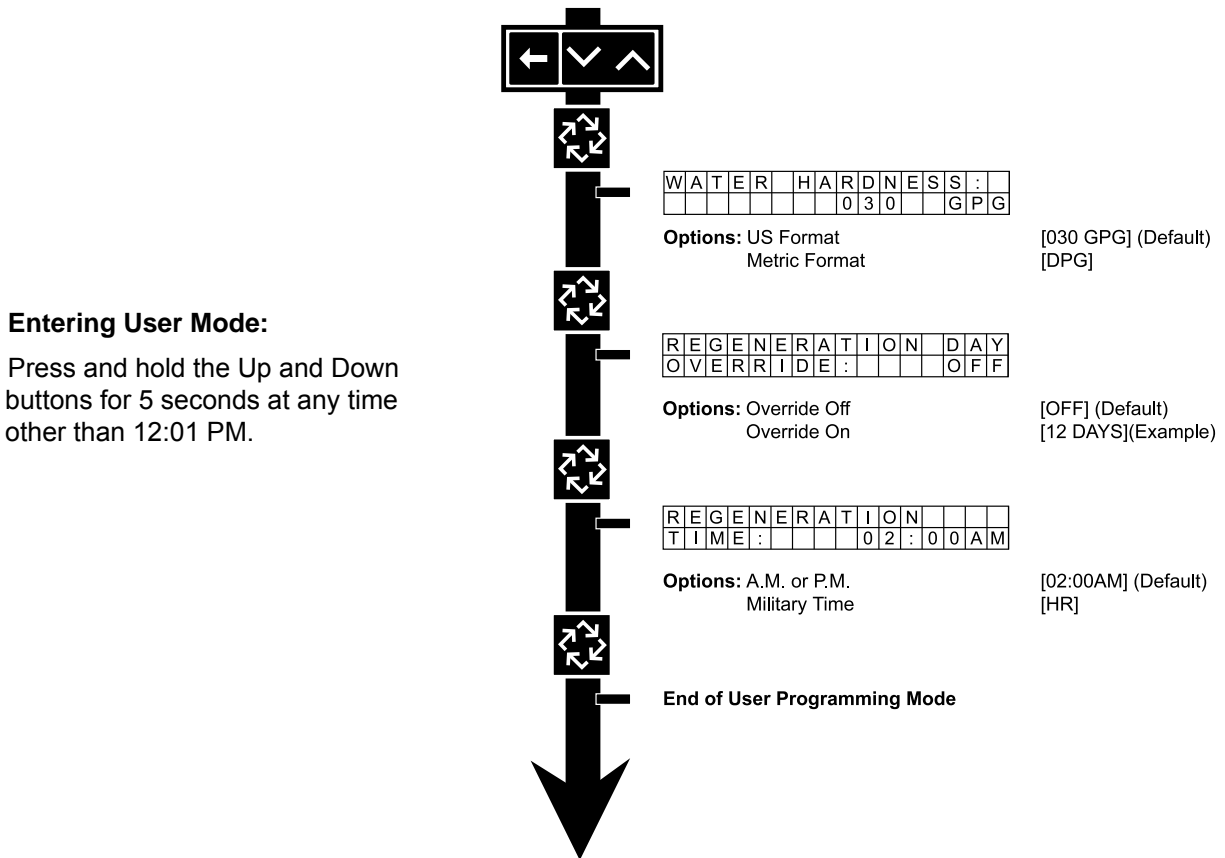

NOTE: Depending on current option settings, some displays cannot be viewed or set.

1. Enter User Mode

- Press and hold the Up and Down buttons for 5 seconds.

2. Set Feed Water Hardness

- Press the Shift, Up, and Down buttons to move the cursor and change the value of the numbers.
- Press the Extra Cycle button to proceed to the next step.

NOTE: Only displayed when a metered option is chosen under System Type.

3. Set Regeneration Day Override

- To turn on and set the days, press the Down button.
- Press the Shift, Up, and Down buttons to move the cursor and change the value of the numbers.
- Press the Extra Cycle button to proceed to the next step.

4. Regeneration Time

- Press the Shift, Up, and Down buttons to move the cursor and change the value of the numbers.
- Press the Extra Cycle button

5. End of User Programming Mode

Diagnostic Programming Mode Flow Chart

NOTE: Depending on current option settings, some displays cannot be viewed or set.

Entering Diagnostic Mode:

1. Press and release the “D” button.
2. Press the Extra Cycle button once per display until all displays are viewed and the normal display screen appears.
3. Press and release the “D” button during this mode to exit the Diagnostic Mode.
4. Depending on current option settings, some displays cannot be viewed.

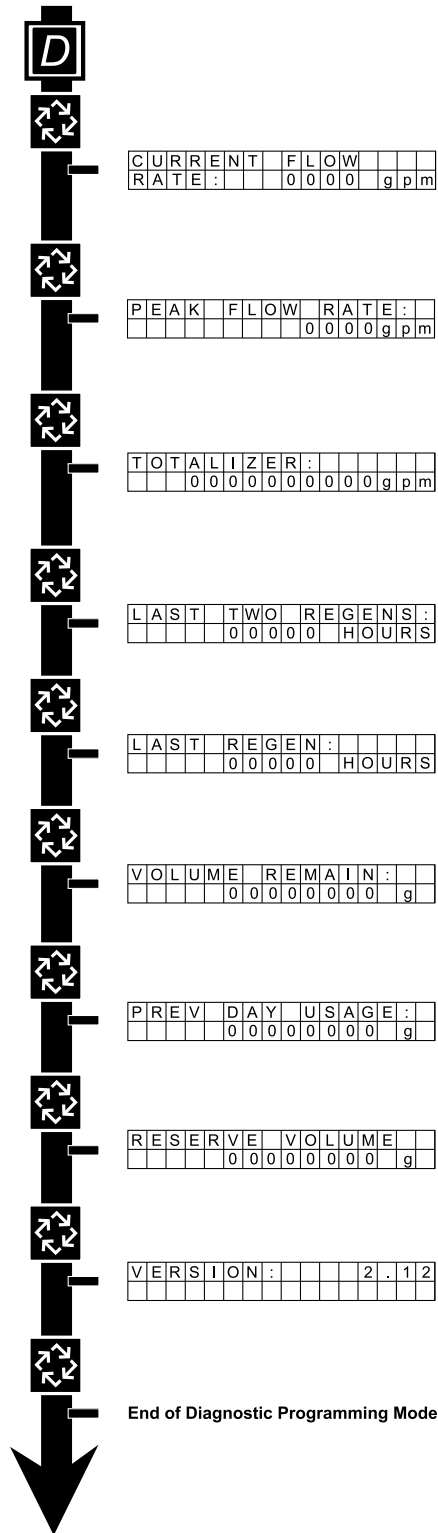

Diagnostic Programming Mode

NOTE: Depending on current option settings, some displays cannot be viewed.

Overview Diagnostic Mode

The current Diagnostic Programming Mode screen will display until either the Extra Cycle button is pressed through for each screen, or the Diagnostic button is pressed. In the event of regeneration occurring while in the Diagnostic Programming Mode, the regeneration step and time remaining will be displayed. When regeneration completes, the display will return to the normal time of day display screen.

Entering and Exiting Diagnostic Mode

Press and release the “D” button to enter the Diagnostic Programming Mode. Pressing the Extra Cycle button will move to the next diagnostic screen. Press the Extra Cycle button once per display until all are viewed. Pressing the Diagnostic button while in Diagnostic Mode will cause the unit to leave the Diagnostic Mode and return to the normal time of day display screen.

1. Current Flow Rate

This program step displays the calculated flow rate for the timer. The below flow rates are the maximum flow rate the timer will read for each meter.

.75” Paddle:	15 gpm (0.06 m3/m)	.75” Turbine:	15 gpm (0.06 m3/m)
1” Paddle:	40 gpm (0.15 m3/m)	1” Turbine:	90 gpm (0.34 m3/m)
1.5” Paddle:	180 gpm (0.68 m3/m)	1.5” Turbine:	90 gpm (0.34 m3/m)
2” Paddle:	350 gpm (1.32 m3/m)		
3” Paddle:	500 gpm (1.89 m3/m)		

— Press the Extra Cycle button.

2. Peak Flow Rate

This program step displays the peak flow rate (1 minute average) since the last regeneration.

— Press the Extra Cycle button.

3. Totalizer

This program step displays the total volume of treated water that passes through the meter.

— Reset to zero by holding the Up and Down buttons for five seconds while in the totalizer screen.

— Press the Extra Cycle button.

4. Hours Between Last Two Regenerations

This program step displays the time between the last two regenerations saved.

— Press the Extra Cycle button.

5. Hours Since Last Regeneration

This program step displays the hours since the last regeneration.

— Press the Extra Cycle button.

6. Volume Remaining

This program step displays the volume remaining. The timer will regenerate if the volume remaining is set to zero. The maximum ranges are the same as the maximum volume calculated on the main screen.

— Press the Extra Cycle button.

7. Previous Day’s Water Usage

This program step displays the previous day’s water usage.

— Press the Extra Cycle button.

8. Reserve Volume

This program step displays the reserve capacity, ensuring soft water is available at all times.

— Press the Extra Cycle button.

9. Software Version

This program step displays the timer’s software program version number.

— Press the Extra Cycle button to exit.

NOTE: Diagnostic Programming Mode will stop if the system goes into a regeneration.

2510/2750/2850 Power Head Assy

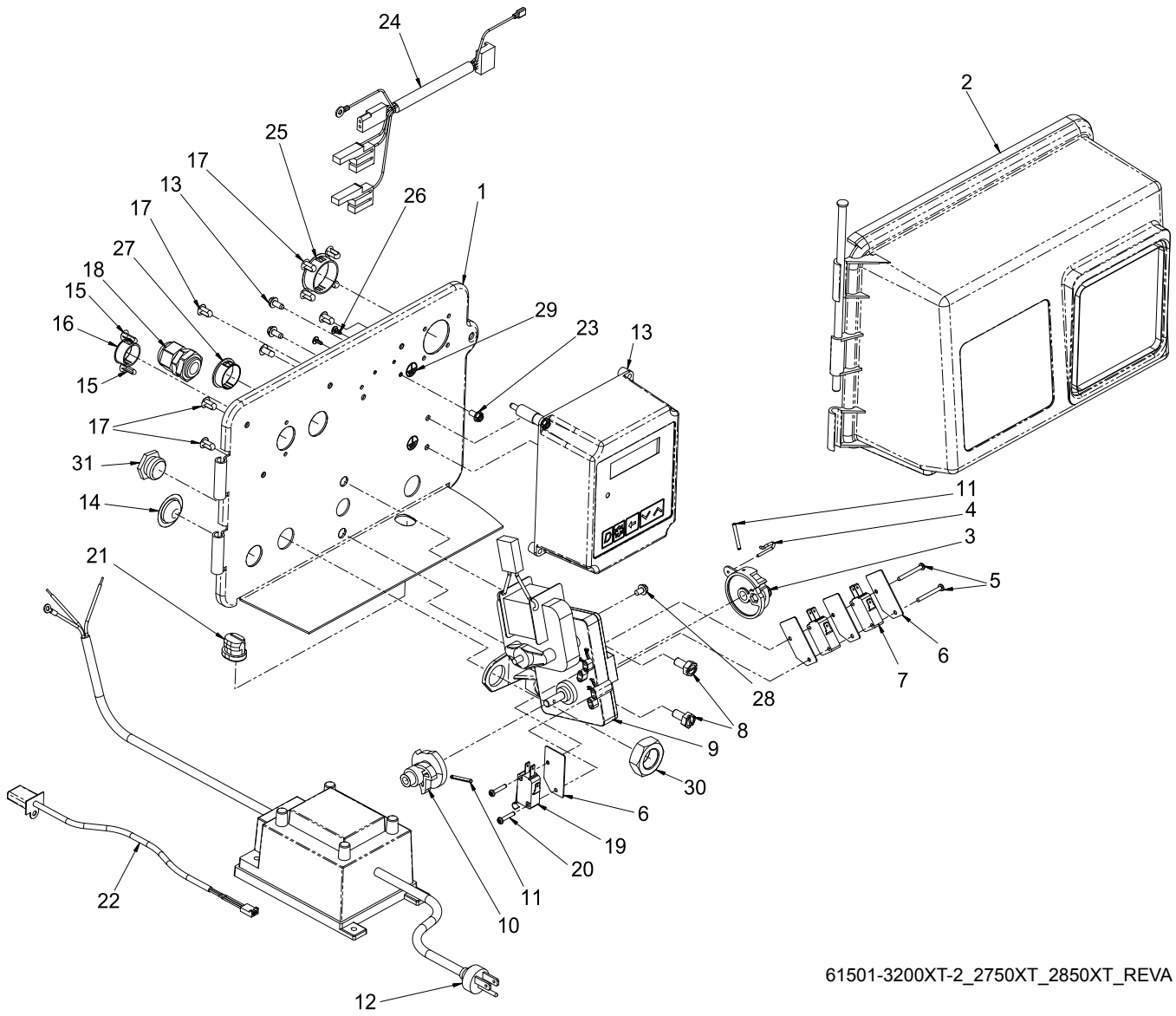

61501-3200XT-2_2750XT_2850XT_REVA

2510/2750/2850 Lower Power Head Assy

Item No.	Quantity	Part No.	Description
1	1	18697-15	Backplate, Hinged
2	1	60219-02	Cover Assy, Environmental, Black w/Clear Window
3	1	60160-10	Drive Cam Assy, STF, Black
4	1	10909	Pin, Link
5	2	14923	Screw, Pan Hd Mach, 4-40 x 1
6	4	10302	Insulator, Limit Switch
7	2	10218	Switch, Micro
8	2	10231	Screw, Slot Hex, 1/4 -20 x 1/2
9	1	41544	Motor, Drive, 24V, 50/60 Hz
10	1	12777	Cam, Shut-Off Valve
11	2	10338	Pin, Roll, 3/32 x 7/8
12	1	41034	Transformer, US 120V/24V, 108VA
	1	41049	Transformer, Euro, 230V/24V
	1	41050	Transformer, Aust, 230V/24V
13	1	42466-01	Timer Assy, XT, Right Hand
14	1	19691	Plug, .750 Dia, Recessed, Black
15	2	19800	Plug, .140 Dia, White
16	1	15806	Plug, Hole, Heyco #2693
17	9	19801	Plug, .190 Dia, White
18	1	17967	Fitting Assy, Liquid Tight, Blk
19	1	10896	Switch, Micro
20	2	11805	Screw, Rd Hd, 4-40 x 5/8 Type 1
21	1	13547	Strain Relief, Flat Cord
22	1	19791-02	Meter Cable Assy, Softflow
	1	19791-04	Meter Cable Assy, Turbine 100"
	1	19791-05	Meter Cable Assy, Turbine 304"
	1	19121-08	Meter Cable Assy, NT, 35" w/Connector
	1	19121-09	Meter Cable Assy, NT, 99.5" w/Connector
	1	19121-10	Meter Cable Assy, NT, 303.5" w/Connector
23	1	14202-01	Screw, Hex Wsh Mach, 8-32 x 5/16
24	1	40941	Wire Harness, Upper Drive
25	1	17421	Plug, 1.20 Hole
26	2	41581	Plug, Hole, .125 Dia, White
27	1	16493	Plug, Hole, Heyco
28	1	10872	Screw, Hex Wsh, 8-32 x 17/64
29	1	41102	Label, 3900NT, Ground
30	1	10269	Nut, Jam, 3/4 - 16
31	1	10712	Fitting, Brine Valve

NOTE: For all other service part numbers, see the Service Manual that accompanies the control valve.

2900s Power Head Assy

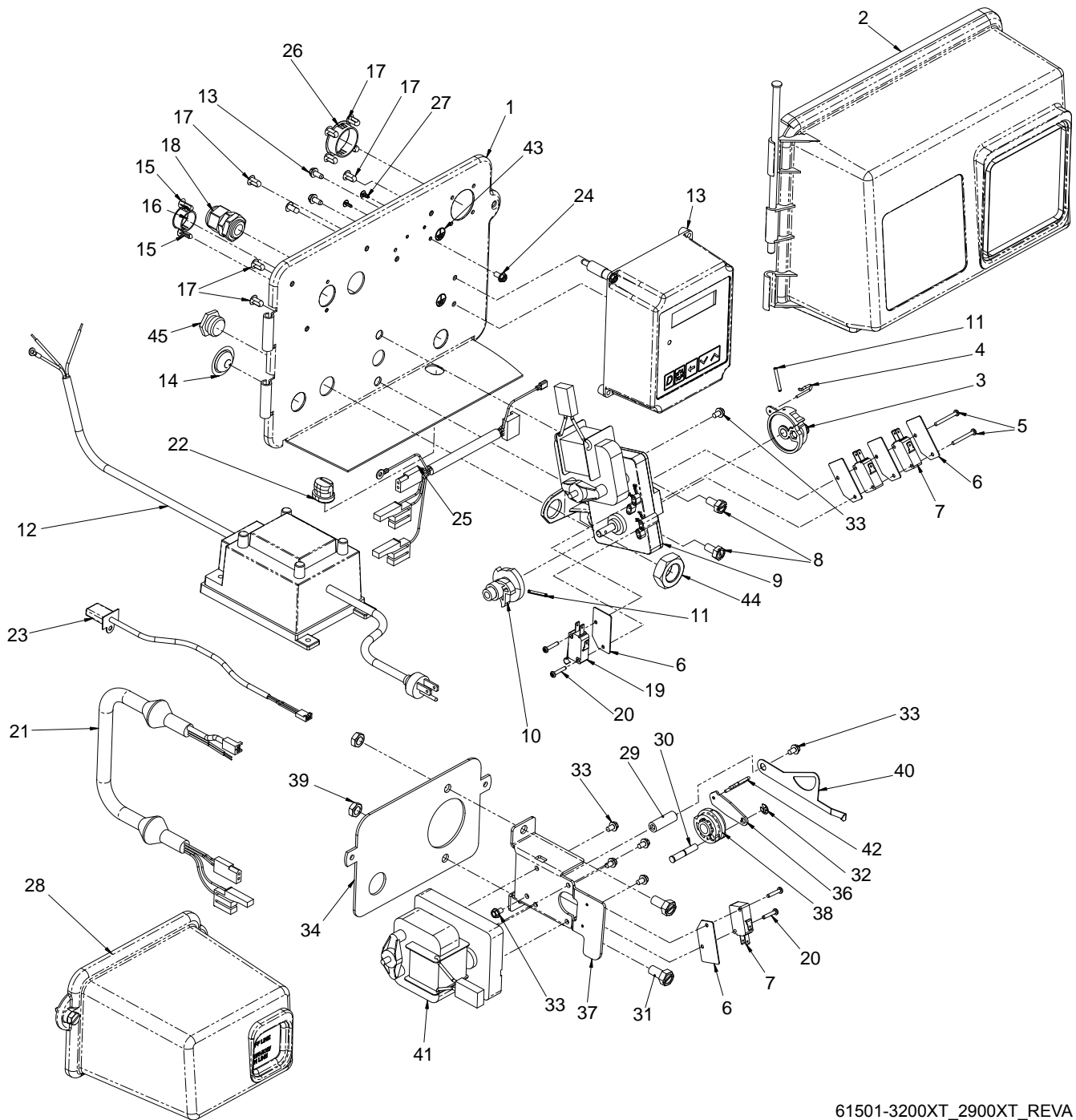

61501-3200XT_2900XT_REVA

2900s Power Head Assy

Item No.	Quantity	Part No.	Description
1	1	18697-15	Backplate, Hinged
2	1	60219-02	Cover Assy, Environmental, Black
3	1	60160-10	Drive Cam Assy, STF, Black
4	1	10909	Pin, Link
5	2	14923	Screw, Pan Hd Mach, 4-40 x 1
6	5	10302	Insulator, Limit Switch
7	3	10218	Switch, Micro
8	2	10231	Screw, Slot Hex, 1/4 - 20 x 1/2
9	1	41544	Motor, Drive, 24V/50-60 Hz
10	1	12777	Cam, Shut-Off Valve
11	2	10338	Pin, Roll, 3/32 x 7/8
12	1	41034	Transformer, US, 120V/24V, 108VA
		41049	Transformer, Euro, 230V/24V
		41050	Transformer, Aust, 230V/24V
13	1	42466-01	Timer Assy, XT, Right Hand
14	1	19691	Plug, .750 Dia Hole, Flush
15	2	19800	Plug, .140 Dia, White
16	1	15806	Plug, Hole, Heyco #2693
17	9	19801	Plug, .190 Dia, White
18	1	17967	Fitting Assy, Liquid Tight, Blk
19	1	10896	Switch, Micro
20	4	11805	Screw, Rd Hd, 4-40 x 5/8 Type 1
21	1	40943	Wire Harness, Lower Drive
22	1	13547	Strain Relief, Flat Cord
23	1	19121	Meter, Cable Assy, 3200NT
		19121-08	Meter Cable Assy, NT, 35" w/Connector
		19121-09	Meter Cable Assy, NT, 99.5"
		19121-10	Meter Cable Assy, NT, 303.5"
24	1	14202-01	Screw, Hex Wsh Mach, 8-32 x 5/16
25	1	40941	Wire Harness, Upper Drive
26	1	17421	Plug, 1.20 Hole
27	2	41581	Plug, Hole, .125 Dia, White
28	1	60217-02	Cover Assy, 2900, Lower, Black
29	1	18726	Spacer, Indicator
30	1	18746	Bearing, Connector Rod
31	2	11224	Screw, Hex Hd, 5/16 - 18 x 5/8
32	1	10250	Ring, Retaining
33	7	10872	Screw, Hex Wsh, 8-32 x 17/64
34	1	18709	Backplate, Lower
35	1	11381	Pin, Roll, 2900/3900
36	1	14759	Link, Piston Rod
37	1	14769	Bracket, Motor, 2900
38	1	14775	Cam, Drive, 2900
39	2	16346	Nut, Hex, Jam, 5/16 - 18, 18-8 SS
40	1	18725	Indicator, Service/Standby
41	1	40338	Motor, Drive, 24V, 50/60 Hz, SP
42	1	14813	Pin, Spring, Connecting Rod
43	1	41102	Label, 3200NT, Ground
44	1	10269	Nut, Jam, 3/4 - 16
45	1	10712	Fitting, Brine Valve

NOTE: For all other service part numbers, see the Service Manual that accompanies the control valve.

3150 Power Head Assy

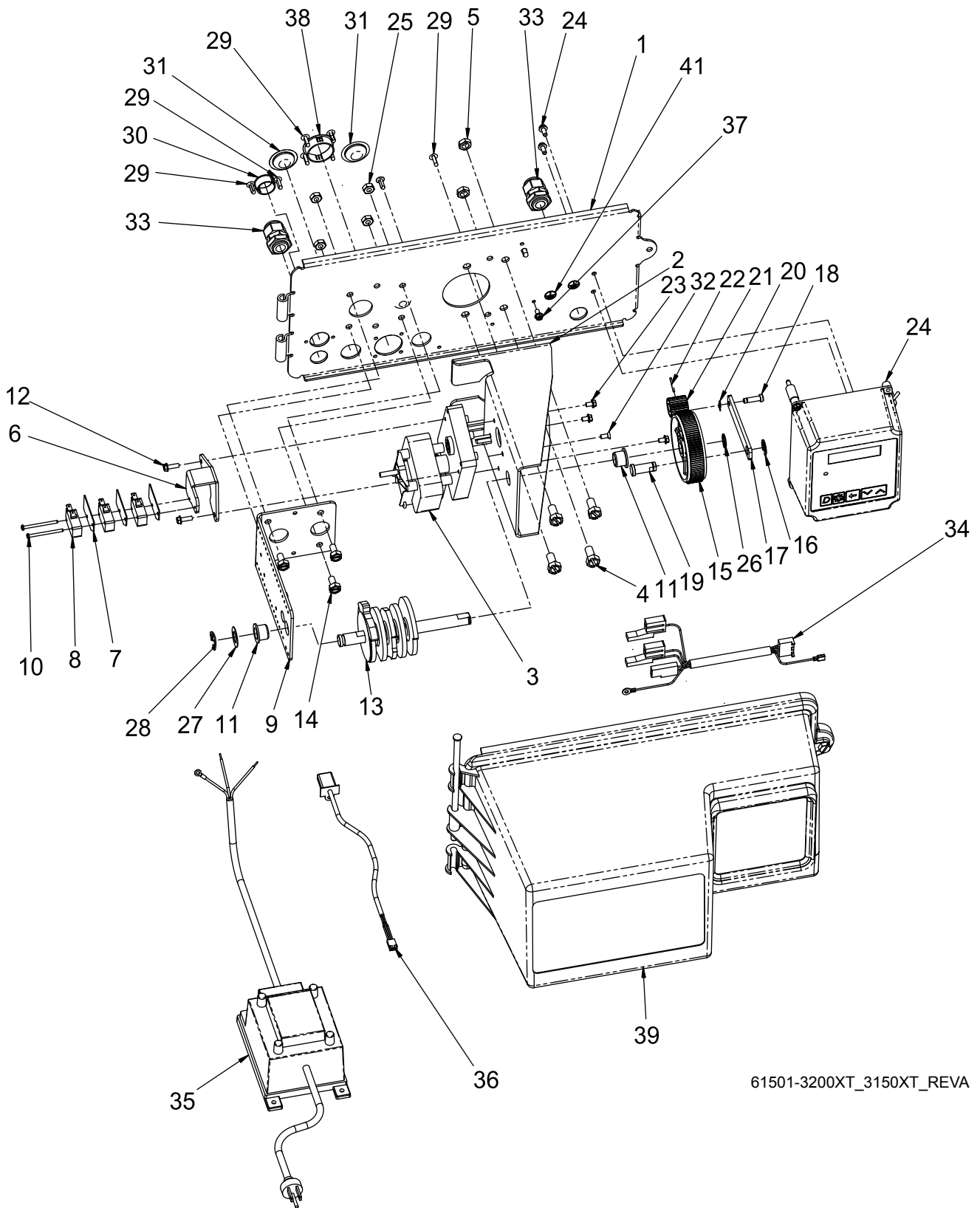

61501-3200XT_3150XT_REVA

3150 Power Head Assy

Item No.	Quantity	Part No.	Description
1	1	19304-04	Backplate, 3150/3900 Upper
2	1	15120	Bracket, Motor Mtg, 3150/3900
3	1	40391	Motor, Drive, 24V, 50/60 Hz
4	4	11224	Screw, Hex Hd, 5-16 - 18 x 5/8
5	2	16346	Nut, Hex, Jam, 5/16 - 18
6	1	17797	Bracket, Switch, Mounting, 3150/3900
7	3	10302	Insulator, Limit Switch
8	3	10218	Switch, Micro
9	1	16053	Bracket, Brine Side
10	2	12624	Screw, Phil Pan, 40 x 1 1/2
11	2	16052	Bushing, 3150/3900
12	2	17567	Screw, Hex Wsh Hd, 8 x 1/2
13	1	16494	Cam Assembly, 3150/3900
14	4	10231	Screw, Slot Hex, 1/4 - 20 x 1/2
15	1	16046	Gear, Drive
16	1	11774	Ring, Retaining
17	1	16047	Link, Drive
18	1	11709	Pin, Drive Link
19	1	16048	Bearing, Drive Link
20	1	11898	Clip, 3150/3900
21	1	16045	Pinion, Drive
22	1	11381	Pin, Roll, 2900/3900
23	3	10872	Screw, Hex Wsh, 8-32 x 17/64
24	1	42466-01	Timer Assy, XT, Right Hand
25	4	11235	Nut, Hex, 1/4 - 20, Mach Screw
26	1	16050	Ring, Retaining
27	1	16059	Washer, SS, .88, 3150/3900
28	1	16051	Ring, Retaining, Bowed
29	8	19800	Plug, .140 Dia, White
30	1	15806	Plug, Hole, Heyco, #2693
31	2	19591	Plug, .875 Hole, Recessed, Black
32	1	11080	Screw, Flt Hd Mach, 8-32 x 3/8
33	2	17967	Fitting Assy, Liquid Tight, Blk
34	1	40941	Wire Harness, Upper Drive
35	1	41034	Transformer, US, 120V/24V, 108VA
		41049	Transformer, Euro, 230V/24V
		41050	Transformer, Aust, 230V/24V
36	1	19121	Meter, Cable Assy, 3200NT
		19121-08	Meter Cable Assy, NT, 35" w/Connector
		19121-09	Meter Cable Assy, NT, 99.5"
		19121-10	Meter Cable Assy, NT, 303.5"
37	1	14202-01	Screw, Hex Wsh Mach, 8-32 x 5/16
38	1	17421	Plug, 1.20 Hole
39	1	60240-02	Cover Assy, 3150/3900, Env, Black
41	1	41102	Label, 3200NT, Ground
42	1	19801	Plug, .190 Dia, White
43	1	19691	Plug, .750 Dia, Recessed, Black

NOTE: For all other service part numbers, see the Service Manual that accompanies the control valve.

3900 Power Head Assy

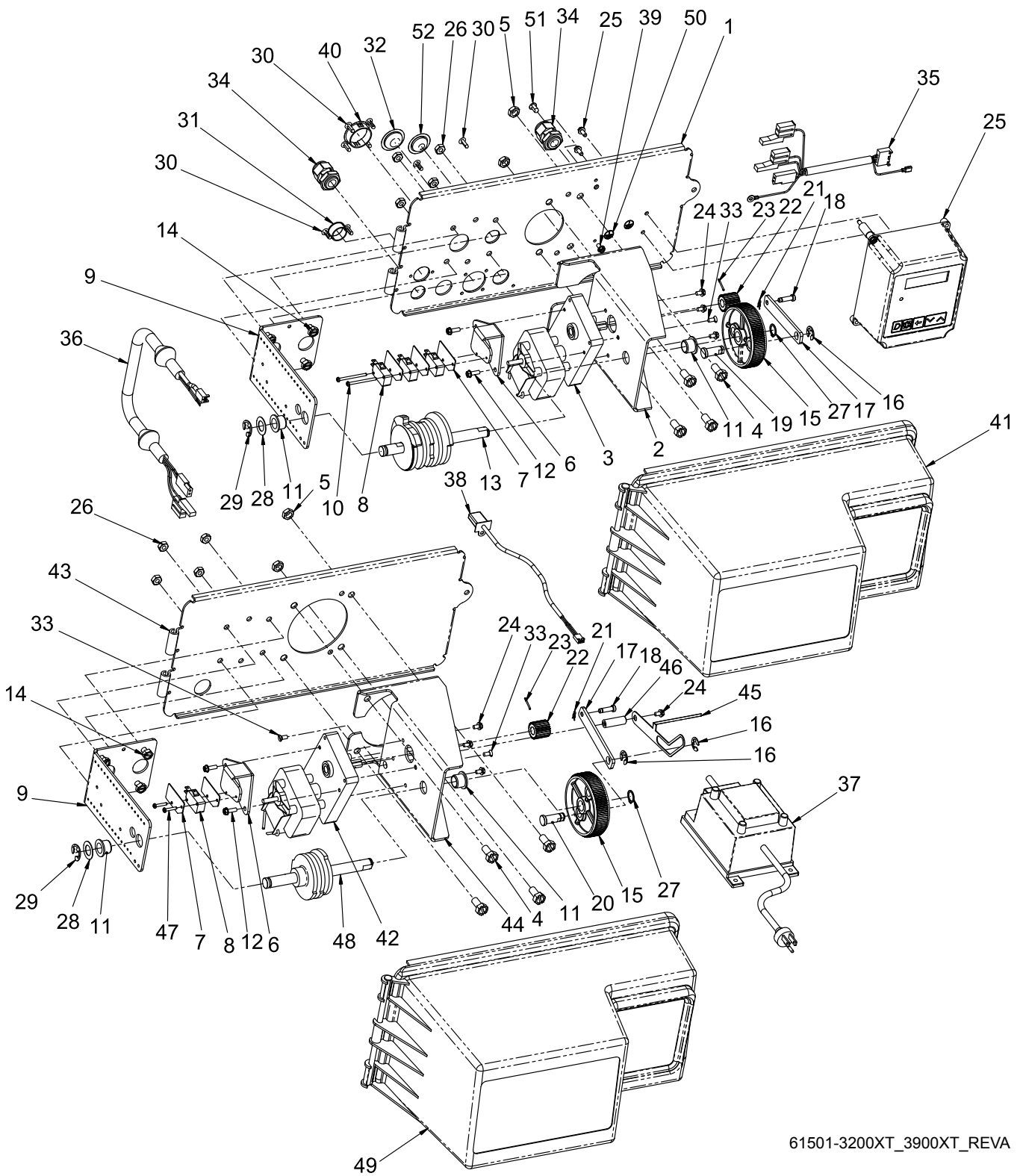

61501-3200XT_3900XT_REVA

3900 Power Head Assy

Item No.	Quantity	Part No.	Description
1	1	19304-04	Backplate, 3150/3900 Upper
2	1	15120	Bracket, Motor Mtg, 3150/3900
3	1	40391	Motor, Drive, 24V, 50/60 Hz
4	8	11224	Screw, Hex Hd, 5-16 - 18 x 5/8
5	4	16346	Nut, Hex, Jam, 5/16 - 18
6	2	17797	Bracket, Switch, Mounting, 3150/3900
7	5	10302	Insulator, Limit Switch
8	4	10218	Switch, Micro
9	2	16053	Bracket, Brine Side
10	2	12624	Screw, Phil Pan, 40 x 1 1/2
11	4	16052	Bushing, 3150/3900
12	4	17567	Screw, Hex Wsh Hd, 8 x 1/2
13	1	16494	Cam Assembly, 3150/3900
14	8	10231	Screw, Slot Hex, 1/4 - 20 x 1/2
15	2	16046	Gear, Drive
16	3	11774	Ring, Retaining
17	2	16047	Link, Drive
18	2	11709	Pin, Drive Link
19	1	16048	Bearing, Drive Link
20	1	16048	Bearing, Drive Length, 3900
21	2	11898	Clip, 3150/3900
22	2	16045	Pinion, Drive
23	2	11381	Pin, Roll, 2900/3900
24	7	10872	Screw, Hex Wsh, 8-32 x 17/64
25	1	42466-01	Timer Assy, XT, Right Hand
26	8	11235	Nut, Hex, 1/4 - 20, Mach Screw, Zinc
27	2	16050	Ring, Retaining
28	2	16059	Washer, SS, .88, 3150/3900
29	2	16051	Ring, Retaining, Bowed
30	8	19800	Plug, .140 Dia, White
31	1	15806	Plug, Hole, Heyco #2693
32	1	19591	Plug, .875 Hole, Recessed, Black
33	3	11080	Screw, Flt Hd Mach, 8-32 x 3/8
34	2	17967	Fitting Assy, Liquid Tight, Blk
35	1	40941	Wire Harness, Upper Drive
36	1	40943	Wire Harness, Lower Drive, w/Molded Strain Relief
37	1	41034	Transformer, US, 120V/24V, 108VA
		41049	Transformer, Euro, 230V/24V
		41050	Transformer, Aust, 230V/24V
38	1	19121	Meter, Cable Assy, 3200NT
		19121-09	Meter Cable Assy, NT, 99.5"
		19121-10	Meter Cable Assy, NT, 303.5"
39	1	14202-01	Screw, Hex Wsh Mach, 8-32 x 5/16
40	1	17421	Plug, 1.20 Hole
41	1	60240-02	Cover Assy, 3150/3900, Env, Black
42	1	40392	Motor, Drive, 115V, 50/60 Hz, SP
43	1	19305	Backplate, 3900, Lower, Env
44	1	16086	Bracket, Motor Mounting
45	1	19315	Indicator, Service/Standby
46	1	18726	Spacer, Indicator
47	2	11805	Screw, Rd Hd, 4-40 x 5/8 Type 1
48	1	16495	Cam Assy, 3900, Lower
49	1	60240-22	Cover Assy, 3900, Lower, Env
50	1	41102	Label, 3200NT, Ground
51	1	19801	Plug, .190 Dia, White
52	1	19691	Plug, .750 Dia, Recessed, Black

NOTE: For all other service part numbers, see the Service Manual that accompanies the control valve.

9000/9100/9500 Power Head Assy

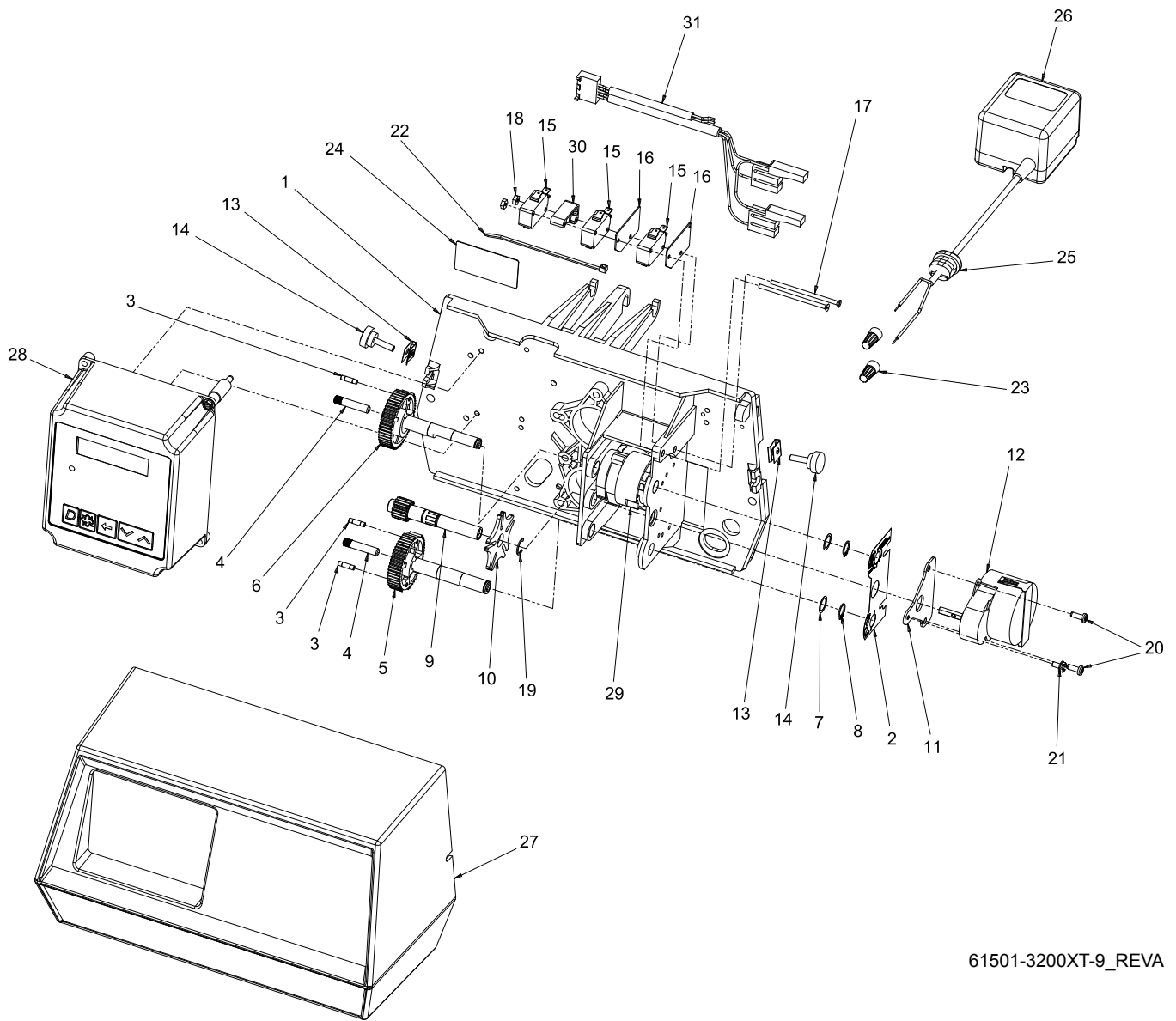

61501-3200XT-9_REVA

9000/9100/9500 Power Head Assy

Item No.	Quantity	Part No.	Description
1	1	17784-05	Panel, Control, 9000/9500, ET
2	1	15175	Label, Shaft Position
3	3	15209	Pin, Roll, 1/8 x 1/2 SS
4	2	15367	Pin, Dowel, 9000
5	1	17869	Gear, Drive, 1/2" Stroke
6	1	17868	Gear, Drive, 3/4" Stroke, 9000
7	2	15692	Washer, Plain, 3/8"
8	2	14917	Ring, Retaining
9	1	15135	Gear, Drive, 9000
10	1	14896	Wheel, Geneva
11	1	15199	Plate, Ground, 9000/9500
12	1	18737	Motor, 24V, 50/60 Hz, 1 RPM
13	2	18728	Nut, Tinneman, U Type, 8-32
14	2	19367	Screw, Designer Cover, Thumb
15	3	16433	Switch, Miniature
16	2	10302	Insulator, Limit Switch
17	2	16442	Screw, Slot Flat Hd, 4-40 x 2.12"
18	2	10339	Nut, Hex, 4-40 Zinc Plated
19	1	15810	Ring, Retaining
20	2	19160	Screw, Phil Pan, Thread, 6-32 x 3/8
21	1	14430	Screw, Hex Wsh St, 6 x 1/4
22	1	14044	Tie, Cable, Heyco VNT# 4-18
23	2	40422	Nut, Wire, Tan
24	1	41587	Label, Serial Number, Stock
25	1	13547-01	Strain Relief, Euro Round Cord
26	1	19674	Transformer, 24V, 9.6VA
27	1	60232-112	Cover, Designer, 1 Pc Black
28	1	42466-02	Timer Assy, XT, Left Hand
29	1	17765	Cam Assy, Aux Switch, 9500
30	1	18803-01	Spacer, Switch, Machd
31	1	42197	Wire Harness, 5066, 50DP, 9000, 9100, 9500 XT
Not Shown:			
	1	19121-08	Meter Cable Assy, NT, 35" 2/Connector
	1	19791-02	Meter Cable Assy, 35"

NOTE: For all other service part numbers, see the Service Manual that accompanies the control valve.

Single Piston Wiring Diagram

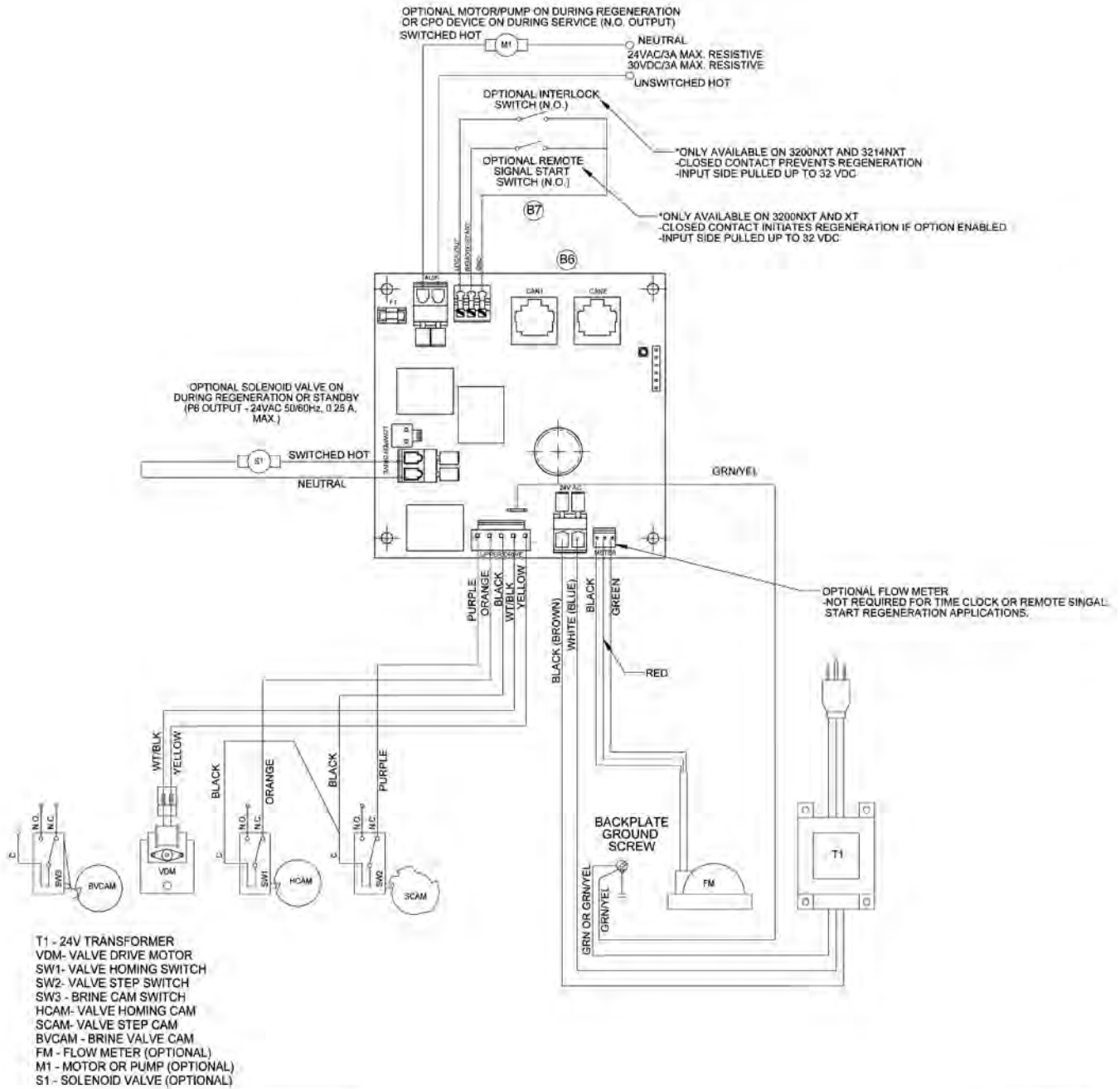

NOTE:
1. TRANSFORMER FUSE - 5A 250V SLOW-BLOW P/N 41143
2. VALVE SHOWN IN SERVICE

4214Q_REV0

Dual Piston Wiring Diagram

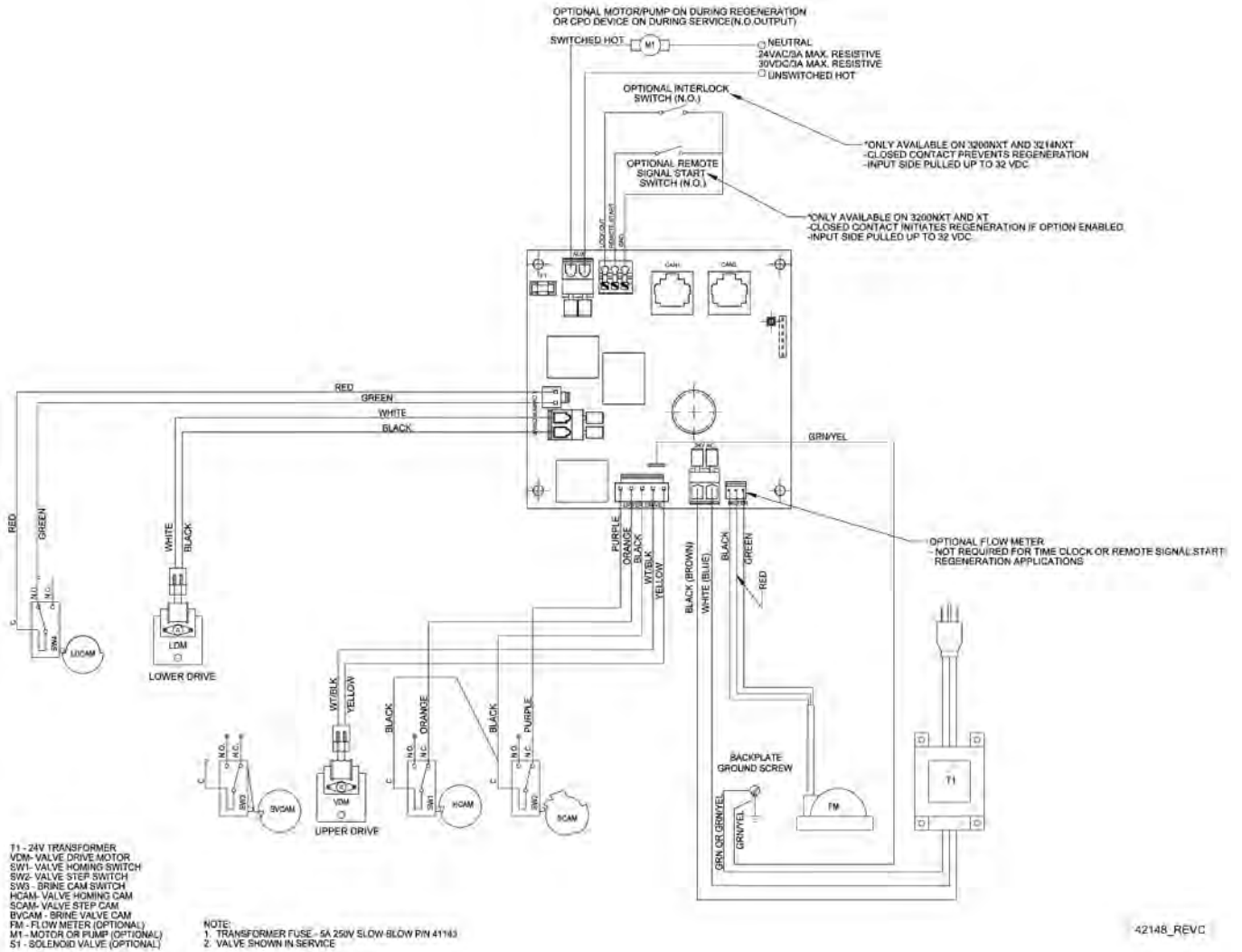

42148_REV C

Troubleshooting - Timer

If an error is detected, an error screen will alternate with the main display screen every few seconds, and the **LED light will be red**.

During an error condition, the unit continues to monitor the flow meter and update the remaining capacity. Once an error condition is corrected, the unit returns to the operating status it was in prior to the error, and regeneration resumes according to normal programming. If an error is cleared by reprogramming the unit in the Master Programming Mode, the volume remaining may be reset to the full unit capacity (as though it had just regenerated). If an error is present, a regeneration can only occur manually by pressing and holding the Extra Cycle button for 5 seconds. If the unit was in regeneration when the error occurred, it will complete the regeneration cycle and go into service.

When the problem is corrected, and the error no longer displays (it may take several seconds for the unit to stop displaying the error message), the unit will return to normal operation. The **LED light** will no longer be **red**, and will turn **Green** if the unit is regenerating, or **Blue** if the unit is in service.

Problem	Correction
A. Flashing/blinking display	A. Power outage has occurred. Either wait 5 minutes for blinking to stop, or press any key on the keypad.
B. Unit not responding after going into regeneration	B. Verify the unit is configured correctly (ex: wiring valve type). Perform a Master Reset by holding the Shift button and cycling power. Check and verify the choices selected in Master Programming Mode.
C. Unit displays "ERROR CODE: REPLACE UNIT" (corrupted UAP)	C. Contact your local water treatment professional.

Error Codes

Error Code	Display Message	Correction
01	ERROR CODE: PROGRAM UNIT	Go through all screens in Master Programming Mode.
02	ERROR CODE: PROGRAM UNIT	Go through all screens in Master Programming Mode.
03	ERROR CODE: SERVICE UNIT	Perform a Master Reset by holding the Shift button and cycling power. Go through all screens in Master Programming Mode. Manually initiate a regeneration cycle by pressing the Extra Cycle button for 5 seconds.
04	ERROR CODE: SERVICE UNIT	Perform a Master Reset by holding the Shift button and cycling power. Go through all screens in Master Programming Mode. Manually initiate a regeneration cycle by pressing the Extra Cycle button for 5 seconds.
05	ERROR CODE: SERVICE UNIT	Call your local water treatment professional as soon as possible. Leave the unit running (do not unplug).

NOTE: If the above corrections do not work, please contact your local water treatment professional.

Error Display Screen Examples

E	R	R	O	R		C	O	D	E	:				
S	E	R	V	I	C	E		U	N	I	T			

E	R	R	O	R		C	O	D	E	:				
P	R	O	G	R	A	M		U	N	I	T			

E	R	R	O	R		C	O	D	E	:				
R	E	P	L	A	C	E		U	N	I	T			

Notes

Notes
